

Spool Valve Hydraulic Motors
Series S

10.2014



inspired hydraulics.

S Series (103-)

Highlights

New, improved design!

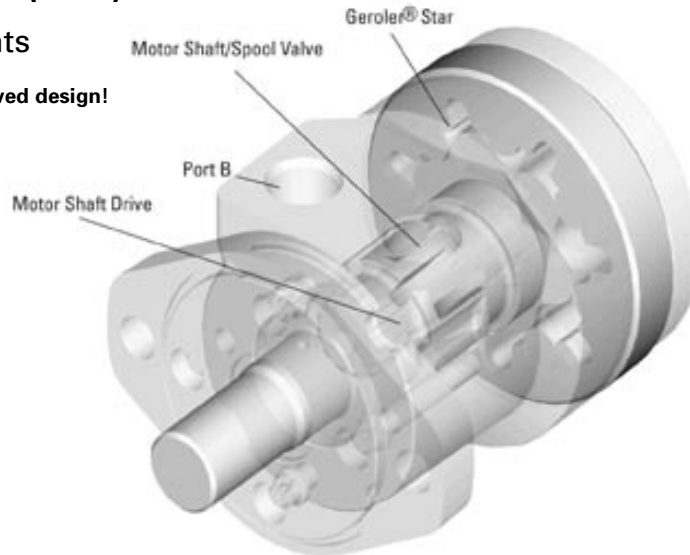

Description

The new improved Char-Lynn S Series motors with optimized Geroler geometry offers enhanced performance with reduced drive-running angle while retaining the overall package size of the original S series. Design improvements include upgraded steel end cap, O-Ring section seals, and optimized Geroler set. The Geroler set has precision-machined rollers in the outer ring which provide support with rolling contact between the star and ring. This improves mechanical efficiency, especially at start-up and at low speed conditions. Improvements incorporated into the latest S Series motor provide reliable leak-free performance and smooth operation at start-up conditions.

Specifications

Geroler Element	10 Displacements
Flow l/min [GPM]	55 [15] Continuous*** 75 [20] Intermittent**
Speed	Up to 963 RPM
Pressure bar [PSI]	135 [2000] Cont.*** 170 [2500] Inter.**
Torque Nm [lb-in]	528 [4672] Cont.*** 587 [5190] Inter.**

*** Continuous— (Cont.) Continuous rating, motor may be run continuously at these ratings.
** Intermittent— (Inter.) Intermittent operation, 10% of every minute.

Features:

- Constant clearance Geroler, design
- Three moving components (gerotor, drive, shaft)
- Optimized drive running angle
- Three-zone pressure design (inlet, return and case)
- Variety of displacements, shafts and mounts
- Special options to meet customer needs!

Benefits:

- High efficiency
- Smooth low speed operation!
- Extended motor life
- Design flexibility
- Ability to optimize designs for your application needs
- Extended leak-free performance

Applications:

- Agricultural augers, harvesters, seeders
- Car wash brushes
- Food processing
- Railroad maintenance equipment
- Machine tools
- Conveyors
- Industrial sweepers and floor polishers
- Saw mill works
- Turf equipment
- Concrete and asphalt equipment
- Skid steer attachments
- Many more



Conveyor



Casting



Amusement ride



Combine



S Series (103-) Specifications

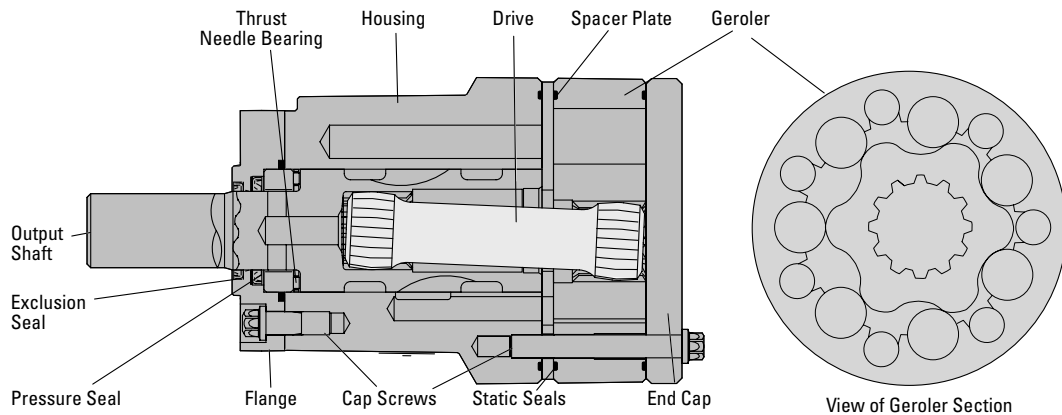

SPECIFICATION DATA — S MOTORS

Displ. cm ³ /r [in ³ /r]		59 [3.6]	75 [4.6]	97 [5.7]	120 [7.3]	144 [8.8]	166 [10.1]	187 [11.4]	225 [13.7]	298 [18.2]	372 [22.7]
Max. Speed (RPM) @ Continuous Flow		963	792	607	472	394	343	304	253	190	153
Flow LPM [GPM]	Continuous	57 [15]	57 [15]	57 [15]	57 [15]	57 [15]	57 [15]	57 [15]	57 [15]	57 [15]	57 [15]
	Intermittent	68 [18]	76 [20]	76 [20]	76 [20]	76 [20]	76 [20]	76 [20]	76 [20]	76 [20]	76 [20]
Torque Nm [lb-in]	Continuous	115 [1021]	150 [1325]	183 [1623]	237 [2010]	265 [2347]	301 [2662]	333 [2950]	372 [3290]	491 [4345]	528 [4672]
	Intermittent	144 [1271]	186 [1649]	225 [1992]	292 [2582]	324 [2870]	360 [3191]	399 [3533]	434 [3843]	505 [4467]	587 [5200]
Min. Starting Torque Nm[lb-in]	@ Cont. Pressure	90 [800]	113 [1000]	148 [1310]	184 [1630]	212 [2050]	232 [2330]	263 [2670]	302 [2990]	338 [3270]	369 [3270]
	@ Int. Pressure	116 [1030]	146 [1290]	190 [1680]	236 [2090]	271 [2400]	289 [2560]	289 [2910]	329 [3310]	374 [3690]	417 [3880]
Pressure Bar [PSI]	Continuous	138 [2000]	138 [2000]	138 [2000]	138 [2000]	131 [1900]	131 [1900]	128 [1850]	117 [1700]	103 [1500]	90 [1300]
	Intermittent	172 [2500]	172 [2500]	172 [2500]	172 [2500]	162 [2350]	159 [2300]	155 [2250]	141 [2050]	124 [1800]	103 [1500]

A simultaneous maximum torque and maximum speed NOT recommended.

Note:

To assure best motor life, run motor for approximately one hour at 30% of rated pressure before application to full load. Be sure motor is filled with fluid prior to any load applications.

Maximum Inlet Pressure:

172 Bar [2500 PSI] without regard to Δ Bar [Δ PSI] and/or back pressure ratings or combination thereof.

6B Splined or Tapered shafts are recommended whenever operating above 282 NM [2500 lb-in] of torque, especially for those applications subject to frequent reversals.

Δ Pressure:

The true Δ bar [Δ PSI] between inlet port and outlet port

Continuous Rating:

Motor may be run continuously at these ratings

Intermittent Operation:

10% of every minute

Recommended Fluids:

Premium quality, anti-wear type hydraulic oil with a viscosity of not less than 70 SUS at operating temperature.

Recommended Maximum System Operating Temp.:

82°C [180°F]

Recommended Filtration:

per ISO Cleanliness Code 4406, level 20/18/13





S Series (103-)

Performance Data

Motors run with high efficiency in all areas designated with a number for torque and speed, however for best motor life select a motor to run with a torque and speed range printed in the light shaded area.

Performance data is typical at 120 SUS. Actual data may vary slightly from unit to unit in production

-  Continuous
-  Intermittent

S Motor 59 cm³/r [3.6 in³/r]

Δ Pressure Bar [PSI]

	[200]	[400]	[600]	[800]	[1000]	[1200]	[1400]	[1600]	[1800]	[2000]	[2500]
	14	28	41	55	69	83	97	110	124	138	172
[2]	86	190	292	390	484	578	662	729	764	803	
7,6	126	121	115	107	97	85	75	63	45	24	
[4]	79	185	289	395	498	600	702	804	903	998	1156
15,1	256	250	243	235	224	212	199	183	166	147	89
[6]	71	177	280	387	495	602	704	808	909	1011	1257
22,7	383	377	369	360	349	336	320	302	284	266	207
[8]	62	166	274	379	488	594	699	806	907	1007	1264
30,3	514	508	500	490	477	464	448	430	409	390	143
[10]	52	155	264	369	475	583	686	793	897	1000	1257
37,9	642	635	628	617	605	591	575	557	538	517	142
[12]	38	141	248	354	462	568	674	777	884	987	1244
45,4	772	764	757	747	736	722	706	687	670	648	592
[14]	21	125	231	337	445	551	658	763	868	972	1233
53,0	900	893	885	876	866	852	836	819	798	778	721
[15]	8	116	223	328	434	543	648	756	862	965	1225
56,8	482	958	949	940	929	915	900	882	863	842	784
[18]		86	191	296	403	511	617	726	831	935	1195
68,1		1151	1139	1128	1117	1105	1090	1074	1054	1033	977

S Motor 75 cm³/r [4.6 in³/r]

Δ Pressure Bar [PSI]

	[200]	[400]	[600]	[800]	[1000]	[1200]	[1400]	[1600]	[1800]	[2000]	[2500]
	14	28	41	55	69	83	97	110	124	138	172
[2]	91	218	343	467	590	708	815	900	981	1086	
7,6	93	89	81	75	66	59	43	21	23	16	
[4]	87	217	352	484	616	748	874	1001	1123	1236	1472
15,1	193	188	181	173	163	150	139	125	107	89	37
[6]	82	219	355	492	627	763	898	1027	1155	1284	1590
22,7	292	286	277	269	258	244	228	214	202	186	140
[8]	69	202	341	481	619	761	896	1032	1165	1296	1618
30,3	390	384	375	364	355	342	326	309	295	276	230
[10]	56	193	330	471	610	751	887	1025	1162	1297	1628
37,9	489	484	476	467	457	444	431	416	399	381	336
[12]	39	175	315	453	595	736	873	1011	1148	1284	1617
45,4	587	582	573	564	552	540	526	510	494	476	427
[14]	12	153	290	431	571	716	856	993	1129	1265	1605
53,0	343	680	673	665	654	641	628	613	594	578	533
[15]	9	143	281	424	567	708	846	985	1121	1259	1599
56,8	491	729	723	714	704	690	675	661	644	628	580
[20]		82	220	362	505	645	784	922	1061	1200	1545
75,7		970	963	957	948	935	921	906	888	871	825

[143] } Torque [lb-in]
16 } Nm
729 } Speed RPM



S Series (103-)

Performance Data

Motors run with high efficiency in all areas designated with a number for torque and speed, however for best motor life select a motor to run with a torque and speed range printed in the light shaded area.

Performance data is typical at 120 SUS. Actual data may vary slightly from unit to unit in production

	Continuous
	Intermittent

S Motor 93 cm³/r [5.7 in³/r]

Δ Pressure Bar [PSI]

	[200]	[400]	[600]	[800]	[1000]	[1200]	[1400]	[1600]	[1800]	[2000]	[2500]
	14	28	41	55	69	83	97	110	124	138	172
[2]	146	308	466	620	771	913	1031	1086	1176	1281	
7,6	16	35	53	70	87	103	116	123	133	145	
	76	72	64	55	48	34	22	7	4	1	
[4]	136	301	466	633	797	959	1116	1275	1430	1570	1798
15,1	15	34	53	72	90	108	126	144	162	177	203
	158	153	146	138	126	115	103	90	77	59	17
[6]	113	278	446	616	786	952	1116	1280	1444	1603	1971
22,7	13	31	50	70	89	108	126	145	163	181	223
	238	232	225	215	206	191	175	161	145	129	87
[8]	98	262	431	604	777	947	1112	1279	1446	1610	2006
30,3	17	30	49	68	88	107	126	144	163	182	227
	319	313	306	296	284	270	255	240	224	208	165
[10]	81	246	415	590	763	935	1100	1271	1439	1604	2012
37,9	9	28	47	67	86	106	124	144	163	181	227
	400	394	388	378	366	353	340	324	306	288	244
[12]	65	232	401	574	746	916	1081	1255	1425	1591	2001
45,4	7	26	45	65	84	103	122	142	161	180	226
	481	476	469	460	448	435	423	408	394	374	326
[14]	42	207	376	552	721	893	1064	1235	1405	1570	1983
53,0	5	23	43	62	81	101	120	140	159	177	224
	561	557	549	541	531	519	504	489	470	455	412
[15]	31	196	364	538	708	881	1052	1223	1391	1560	1974
56,8	4	22	41	61	80	100	119	138	157	176	223
	602	597	591	582	571	559	546	530	514	498	453
[20]	119	290	461	633	807	976	1145	1315	1485	1654	1904
75,7	13	33	52	72	91	110	129	149	168	187	215
	799	792	785	775	762	748	734	717	702	686	660

S Motor 120 cm³/r [7.3 in³/r]

Δ Pressure Bar [PSI]

	[200]	[400]	[600]	[800]	[1000]	[1200]	[1400]	[1600]	[1800]	[2000]	[2500]
	14	28	41	55	69	83	97	110	124	138	172
[2]	191	403	605	801	978	1146	1288	1440	1552	1679	
7,6	22	46	68	91	110	129	146	163	175	190	
	60	56	50	43	36	29	19	15	8	6	
[4]	188	403	617	829	1031	1236	1438	1632	1816	1990	1914
15,1	21	46	70	94	117	140	162	184	205	225	216
	122	118	112	106	98	87	78	67	56	49	16
[6]	172	391	607	821	1030	1241	1449	1654	1858	2056	2522
22,7	19	44	69	93	116	140	164	187	210	232	285
	186	180	175	167	159	149	137	126	114	103	73
[8]	156	375	593	807	1015	1229	1439	1648	1855	2059	2557
30,3	18	42	67	91	115	139	163	186	210	233	289
	249	244	237	229	220	210	199	185	174	162	128
[10]	130	349	567	785	995	1210	1420	1630	1838	2045	2559
37,9	15	39	64	89	112	137	160	184	208	231	289
	311	307	301	293	286	275	264	252	239	227	193
[12]	103	320	539	756	965	1175	1383	1593	1799	2003	2500
45,4	12	36	61	85	109	133	156	180	203	226	282
	374	369	363	355	346	336	327	314	303	288	253
[14]	70	285	502	715	923	1131	1335	1540	1745	1948	2452
53,0	8	32	57	81	104	128	151	174	197	220	277
	437	433	427	419	411	402	391	379	369	355	322
[15]	54	267	485	705	913	1122	1329	1540	1746	1947	2441
56,8	6	30	55	80	103	127	150	174	197	220	276
	469	465	459	452	444	433	423	411	400	386	349
[20]	159	377	600	815	1026	1232	1444	1651	1859	2067	2383
75,7	18	43	68	92	116	139	163	186	210	234	269
	621	618	612	603	594	583	571	560	549	539	515

[267] } Torque [lb-in]
30 } Nm
465 } Speed RPM



S Series (103-)

Performance Data

Motors run with high efficiency in all areas designated with a number for torque and speed, however for best motor life select a motor to run with a torque and speed range printed in the light shaded area.

Performance data is typical at 120 SUS. Actual data may vary slightly from unit to unit in production

	Continuous
	Intermittent

S Motor 144 cm³/r [8.8 in³/r]

Δ Pressure Bar [PSI]

	[200]	[400]	[600]	[800]	[1000]	[1200]	[1400]	[1600]	[1800]	[1900]	[2350]
	14	28	41	55	69	83	97	110	124	138	172
[2]	222	480	729	967	1190	1402	1591	1786	2031	2107	
7,6	25	54	82	109	134	158	180	202	229	238	
	49	45	40	34	29	21	17	13	14	14	
[4]	217	475	728	987	1237	1488	1727	1957	2181	2292	2310
15,1	24	54	82	112	140	168	195	221	246	259	261
	101	97	91	84	77	69	61	52	45	42	22
[6]	193	453	715	976	1234	1494	1746	1995	2239	2358	2867
22,7	22	51	81	110	139	169	197	225	253	266	324
	153	149	143	136	128	119	110	101	91	86	66
[8]	173	434	699	961	1218	1479	1735	1984	2235	2358	2894
30,3	20	49	79	109	138	167	196	224	252	266	327
	205	202	195	187	179	170	160	150	139	134	109
[10]	144	407	673	940	1197	1459	1715	1967	2218	2344	2890
37,9	16	46	76	106	135	165	194	222	251	265	327
	259	254	247	240	231	221	211	202	191	185	158
[12]	118	380	644	907	1167	1429	1685	1941	2194	2319	2878
45,4	13	43	73	102	132	161	190	219	248	262	325
	312	307	301	294	286	277	267	257	246	241	217
[14]	87	346	610	871	1131	1395	1651	1907	2163	2289	2851
53,0	10	39	69	98	128	158	187	215	244	259	322
	363	359	354	346	339	330	319	309	299	293	266
[15]	69	327	592	853	1113	1376	1633	1890	2146	2271	2835
56,8	8	37	67	96	126	156	185	214	242	257	320
	389	386	380	372	364	355	344	336	323	317	289
[20]	200	460	726	987	1251	1512	1770	2025	2153	2153	2724
75,7	23	52	82	112	141	171	200	229	243	243	308
	516	513	507	499	491	480	470	459	454	454	427

S Motor 166 cm³/r [10.1 in³/r]

Δ Pressure Bar [PSI]

	[200]	[400]	[600]	[800]	[1000]	[1200]	[1400]	[1600]	[1800]	[1900]	[2300]
	14	28	41	55	69	83	97	110	124	138	172
[2]	267	563	841	1105	1364	1622	1852	2081	2288		
7,6	30	64	95	125	154	183	209	235	259		
	43	39	35	30	27	21	16	13	13		
[4]	247	544	838	1129	1418	1707	1988	2255	2514	2641	3116
15,1	28	61	95	128	160	193	225	255	284	298	352
	89	85	80	74	68	60	53	47	41	38	28
[6]	217	517	813	1108	1401	1700	1994	2281	2559	2692	3214
22,7	25	58	92	125	158	192	225	258	289	304	363
	134	131	125	120	113	105	96	88	79	75	58
[8]	195	494	794	1089	1387	1687	1983	2269	2552	2691	3239
30,3	22	56	90	123	157	191	224	256	288	304	366
	180	176	171	164	156	147	138	128	118	114	96
[10]	176	477	776	1072	1371	1668	1960	2249	2537	2676	3228
37,9	20	54	88	121	155	188	221	254	287	302	365
	227	222	217	210	203	194	185	175	165	160	136
[12]	136	436	737	1037	1335	1636	1928	2217	2509	2651	3210
45,4	15	49	83	117	151	185	218	251	284	300	363
	272	269	264	258	249	241	233	223	214	208	186
[14]	93	394	696	995	1296	1599	1890	2185	2475	2617	3178
53,0	11	44	79	112	146	181	214	247	280	296	359
	318	315	310	303	296	287	279	269	259	254	230
[15]	73	371	672	973	1272	1575	1867	2159	2453	2596	3158
56,8	8	42	76	110	144	178	211	244	277	293	357
	341	338	333	326	319	309	300	290	280	274	253
[20]	227	527	829	1128	1430	1724	2020	2313	2457	2457	3030
75,7	26	60	94	127	162	195	228	261	278	278	342
	452	449	443	435	426	417	407	396	390	390	366

[371] } Torque [lb-in]
42 } Nm
338 } Speed RPM

Änderungen und Druckfehler vorbehalten · 10.2014 · EN · EATON_Motoren S Series



S Series (103-)

Performance Data

Motors run with high efficiency in all areas designated with a number for torque and speed, however for best motor life select a motor to run with a torque and speed range printed in the light shaded area.

Performance data is typical at 120 SUS. Actual data may vary slightly from unit to unit in production

	Continuous
	Intermittent

S Motor 187 cm³/r [11.4 in³/r]

Δ Pressure Bar [PSI]

	[200]	[400]	[600]	[800]	[1000]	[1200]	[1400]	[1600]	[1800]	[1850]	[2250]
	14	28	41	55	69	83	97	110	124	138	172
[2]	298	627	944	1244	1532	1805	2030	2250	2478		
7,6	34	71	107	141	173	204	229	254	280		
[4]	298	640	969	1291	1607	1919	2219	2511	2799	2869	3411
15,1	34	72	109	146	182	217	251	284	316	324	385
[6]	279	621	953	1283	1608	1930	2243	2551	2850	2922	3502
22,7	32	70	108	145	182	218	253	288	322	330	396
[8]	252	593	928	1257	1579	1905	2224	2542	2855	2932	3539
30,3	28	67	105	142	178	215	251	287	323	331	400
[10]	211	555	888	1217	1546	1872	2193	2516	2831	2909	3518
37,9	24	63	100	138	175	211	248	284	320	329	397
[12]	162	502	835	1164	1490	1818	2139	2463	2780	2857	3476
45,4	18	57	94	131	168	205	242	278	314	323	393
[14]	118	452	786	1117	1443	1772	2095	2417	2736	2814	3438
53,0	13	51	89	126	163	200	237	273	309	318	388
[15]	91	425	759	1089	1418	1747	2068	2389	2708	2786	3410
56,8	10	48	86	123	160	197	234	270	306	315	385
[20]		259	590	925	1255	1585	1907	2229	2552	2633	3265
75,7		29	67	105	142	179	216	252	288	297	369
		403	400	394	387	379	370	359	347	344	319

S Motor 225 cm³/r [13.7 in³/r]

Δ Pressure Bar [PSI]

	[200]	[400]	[600]	[800]	[1000]	[1200]	[1400]	[1600]	[1700]	[2050]
	14	28	41	55	69	83	97	110	124	138
[2]	358	765	1139	1498	1842	2163	2474	2738	2894	
7,6	40	86	129	169	208	244	280	309	327	
[4]	367	774	1177	1577	1956	2325	2680	3022	3191	3753
15,1	41	87	133	178	221	263	303	341	361	424
[6]	348	758	1161	1567	1960	2344	2716	3083	3264	3863
22,7	39	86	131	177	221	265	307	348	369	437
[8]	313	721	1124	1529	1921	2312	2696	3073	3265	3894
30,3	35	81	127	173	217	261	305	347	369	440
[10]	262	669	1069	1473	1859	2247	2627	2997	3184	3810
37,9	30	76	121	166	210	254	297	339	360	430
[12]	203	609	1006	1400	1782	2160	2531	2912	3098	3721
45,4	23	69	114	158	201	244	286	329	350	420
[14]	143	544	938	1324	1700	2079	2452	2824	3008	3639
53,0	16	62	106	150	192	235	277	319	340	411
[15]	106	504	897	1281	1653	2027	2393	2761	2944	3576
56,8	12	57	101	145	187	229	270	312	333	404
[20]		303	697	1091	1477	1854	2214	2581	2765	3399
75,7		34	79	123	167	210	250	292	312	384
		336	334	330	325	318	312	304	298	282

[504]
57 } Torque [lb-in]
251 } Nm
Speed RPM



S Series (103-)

Performance Data

Motors run with high efficiency in all areas designated with a number for torque and speed, however for best motor life select a motor to run with a torque and speed range printed in the light shaded area.

Performance data is typical at 120 SUS. Actual data may vary slightly from unit to unit in production

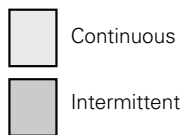

S Motor 298 cm³/r [18.2 in³/r]

Δ Pressure Bar [PSI]

	[200]	[400]	[600]	[800]	[1000]	[1200]	[1400]	[1500]	[1800]
	14	28	41	55	69	83	97	110	124
[2]	487	1009	1509	1991	2460	2931	3360	3577	4113
7,6	55	114	170	225	278	331	380	404	465
	24	22	20	18	17	14	11	10	8
[4]	498	1043	1576	2093	2597	3087	3567	3798	4500
15,1	56	118	178	236	293	349	403	429	508
	49	47	45	41	38	34	31	29	25
[6]	470	1017	1552	2080	2594	3097	3594	3835	4536
22,7	53	115	175	235	293	350	406	433	513
	74	72	69	66	62	57	52	49	42
[8]	423	967	1502	2031	2549	3062	3563	3807	4526
30,3	48	109	165	229	288	346	403	430	511
	100	98	95	92	88	83	77	73	64
[10]	357	901	1433	1961	2477	2989	3486	3730	4456
37,9	40	102	162	222	280	338	394	421	504
	126	124	121	118	113	108	101	97	87
[12]	287	826	1357	1884	2402	2917	3410	3652	4363
45,4	32	93	153	213	271	330	385	413	493
	152	150	147	144	140	134	126	121	109
[14]	199	733	1261	1786	2303	2818	3316	3561	4276
53,0	22	83	142	202	260	318	375	402	483
	177	176	173	170	165	160	152	147	134
[15]	154	688	1218	1742	2258	2771	3273	3518	4241
56,8	17	78	138	197	255	313	370	398	479
	190	189	186	183	178	173	165	160	146
[20]		418	945	1471	1986	2502	3004	3253	3997
75,7		47	107	166	224	283	339	368	452
		253	251	248	244	239	231	226	212

S Motor 372 cm³/r [22.7 in³/r]

Δ Pressure Bar [PSI]

	[200]	[400]	[600]	[800]	[1000]	[1200]	[1400]	[1500]
	14	28	41	55	69	83	97	110
[2]	629	1287	1905	2501	3066	3624	3886	4370
7,6	71	145	215	283	346	409	439	494
	19	18	16	14	13	11	9	7
[4]	628	1304	1962	2600	3206	3799	4082	4642
15,1	71	147	222	294	362	429	461	525
	40	38	36	34	30	27	25	23
[6]	587	1261	1926	2578	3203	3813	4112	4687
22,7	66	142	218	291	362	431	465	530
	60	59	56	54	50	45	43	38
[8]	529	1201	1867	2518	3148	3769	4072	4657
30,3	60	136	211	285	356	426	460	526
	81	79	77	75	71	66	64	58
[10]	451	1124	1779	2429	3056	3678	3983	4583
37,9	51	127	201	274	345	416	450	518
	102	100	98	96	92	86	84	78
[12]	359	1030	1688	2333	2963	3587	3889	4482
45,4	41	116	191	264	335	405	439	506
	122	121	119	117	113	107	104	98
[14]	256	922	1577	2226	2864	3487	3787	4381
53,0	29	104	178	252	324	394	428	495
	143	142	140	137	134	128	126	119
[15]	199	862	1514	2167	2797	3424	3727	4322
56,8	22	97	171	245	316	387	421	488
	153	152	150	148	144	138	135	129
[20]		534	1187	1832	2470	3093	3402	4004
75,7		60	134	207	279	349	384	452
		204	202	200	197	192	189	183

[862] } Torque [lb-in]
97 } Nm
152 } Speed RPM



S Series (103-)

Dimensions

(Refer to pages B-4-19 thru B-4-22 for shaft and port dimensions.)

Ports

7/8-14 SAE O-Ring

6-1/2 (BSP) Straight thread manifold

Standard Rotation Viewed from Shaft End

Port A Pressurized — CW

Port B Pressurized — CCW

2 Bolt Flange

82,55/82,42
[3.250/3.245]
Pilot Dia.

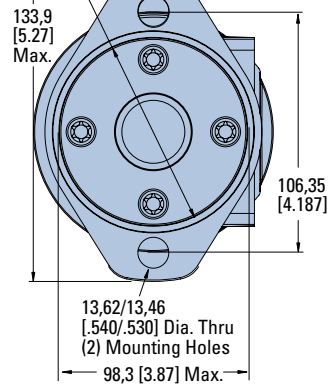

Groove Provided for 82,6 [3.25] I.D. x 2,62 [1.103] Cross Section O-ring (Dash No. 152)

4 Bolt Flange

42,9 [1.69] (2)
85,8 [3.38] Max. (2)

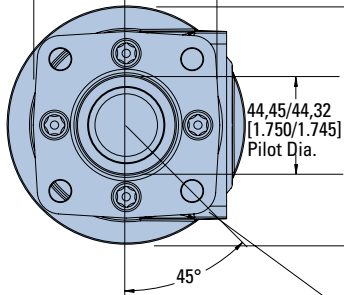

3/8-16 UNC (15,2 [0.60] Max. Bolt Thread Engagement) Mounting Holes (4) Equally Spaced on 82,6 [3.25] Dia. Bolt Circle or M10 x 1,5 (15,2 [0.60] Max. Bolt Thread Engagement) Mounting Holes (4) Equally Spaced on 82,6 [3.25] Dia. Bolt Circle

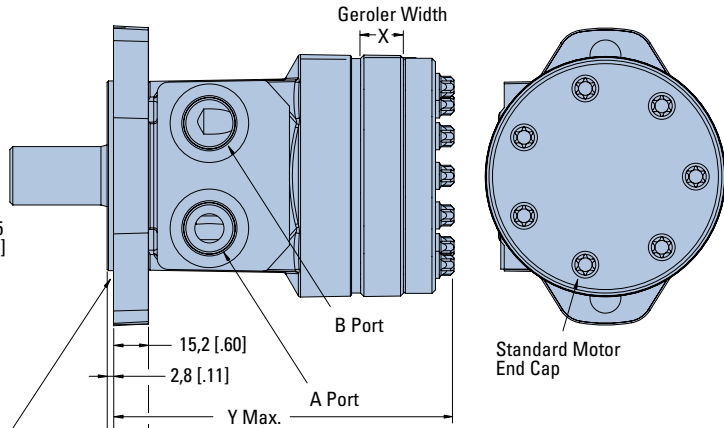

Displacement cm ³ /r [in ³ /r]	X mm [inch]	Y mm [inch]
58 [3.6]	7,5 [0.30]	138,0 [5.43]
76 [4.6]	9,8 [0.39]	140,3 [5.52]
93 [5.7]	12,0 [0.47]	142,5 [5.61]
120 [7.3]	15,5 [0.61]	146,0 [5.75]
144 [8.8]	18,6 [0.73]	149,1 [5.87]
165 [10.1]	21,3 [0.84]	151,8 [5.98]
186 [11.4]	24,0 [0.94]	154,5 [6.08]
225 [13.7]	28,9 [1.14]	159,4 [6.28]
299 [18.2]	38,5 [1.52]	169,0 [6.66]
371 [22.7]	47,9 [1.88]	178,4 [7.02]



S Series (103-) Product Numbers

Use three-digit prefix (103-) plus four-digit number from charts for complete product number (ex: 103-1093). Orders will not be accepted without the three-digit prefix.

2 Bolt Flange

SHAFT	PORT SIZE	DISPL. cm ³ /r [in ³ /r] / PRODUCT NUMBER									
		59 [3.6]	75 [4.6]	93 [5.7]	120 [7.3]	144 [8.8]	166 [10.1]	187 [11.4]	225 [13.7]	298 [18.2]	372 [22.7]
1 in. Straight w/Woodruff Key	7/8-14 O-Ring	103-1537	-1034	-1035	-1538	-1539	-1036	-1037	-1038	-1039	-1040
	1/2 NPTF	103-1540	-1026	-1027	-1541	-1542	-1028	-1029	-1030	-1031	-1032
	Manifold	103-1543	-1042	-1043	-1544	-1545	-1044	-1045	-1046	-1047	-1048
1 in. SAE 6B Splined	7/8-14 O-Ring	103-1552	-1082	-1083	-1553	-1554	-1084	-1085	-1086	-1087	-1088
	1/2 NPTF	103-1555	-1074	-1075	-1556	-1557	-1076	-1077	-1078	-1079	-1080
	Manifold	103-1558	-1090	-1091	-1559	-1560	-1092	-1093	-1094	-1095	-1096

103-1093

4 Bolt Flange

SHAFT	PORT SIZE	DISPL. cm ³ /r [in ³ /r] / PRODUCT NUMBER									
		59 [3.6]	75 [4.6]	93 [5.7]	120 [7.3]	144 [8.8]	166 [10.1]	187 [11.4]	225 [13.7]	298 [18.2]	372 [22.7]
1 in. Straight w/Woodruff Key	7/8-14 O-Ring	103-1570	-1010	-1011	-1571	-1572	-1012	-1013	-1014	-1015	-1016
	1/2 NPTF	103-1573	-1002	-1003	-1574	-1575	-1004	-1005	-1006	-1007	-1008
	Manifold	103-1576	-1018	-1019	-1577	-1578	-1020	-1021	-1022	-1023	-1024
1 in. SAE 6B Splined	7/8-14 O-Ring	103-1579	-1058	-1059	-1580	-1581	-1060	-1061	-1062	-1063	-1064
	1/2 NPTF	103-1582	-1050	-1051	-1583	-1584	-1052	-1053	-1054	-1055	-1056
	Manifold	103-1585	-1066	-1067	-1586	-1587	-1068	-1069	-1070	-1071	-1072

103-1069

S Series Motors with Corrosion Protection

SHAFT	MOUNTING	PORT SIZE	DISPL. cm ³ /r [in ³ /r] / PRODUCT NUMBER									
			59 [3.6]	75 [4.6]	93 [5.7]	120 [7.3]	144 [8.8]	166 [10.1]	187 [11.4]	225 [13.7]	298 [18.2]	372 [22.7]
1 in. Straight w/Woodruff Key	2 Bolt Flange	7/8-14 O-Ring	103-1645	-	-	-	-	-	-	-1649	-	-1650
	4 Bolt Flange	1/2 NPTF	-	-	-	-	-	-	-	-1620	-	-1621

*Manifold product numbers shown are for motors with four 5/16 z-18 port face mounting threads. Manifold, manifold mounting O-Rings and bolts are NOT included.

For S Series Motors with a configuration Not Shown in the charts above: Use the model code number system on page B-3-11 to specify the product in detail.



S Series with Low Speed Valving

Product Number

Motors with the low speed valving option enable very smooth low speed operation while maintaining high torque.

Designed to run continuously at up to 200 RPM at standard rated pressures and reduced flows, this option provides smooth operation at low speeds. Furthermore, they resist slippage and have

more momentary load holding ability than the standard H and S Series motors. Motors with this valving are not intended for low pressure applications (41 Bar [600 PSI] Minimum). Shaft side / radial load ratings are not affected by this valving.

Use digit prefix—103-plus four digit number from charts for complete product number—
Example: 103-2678.

Orders will not be accepted without the three-digit prefix.

2 Bolt Flange

SHAFT	PORT SIZE	DISPL. cm ³ /r [in ³ /r] / PRODUCT NUMBER									
		59 [3.6]	75 [4.6]	93 [5.7]	120 [7.3]	144 [8.8]	166 [10.1]	187 [11.4]	225 [13.7]	298 [18.2]	372 [22.7]
1 in. Straight w/Woodruff Key	7/8 -14 O-Ring	103-	-1427	-1428	—	—	-1429	-1430	-1431	-1432	-1433
	1/2 NPTF	103-	-1419	-1420	—	—	-1421	-1422	-1423	-1424	-1425
	Manifold*	103-	—	—	—	—	—	—	—	—	—
1 in. SAE 6B Splined	7/8 -14 O-Ring	103-	-1525	—	—	-2692	—	—	-1675	—	—
	1/2 NPTF	103-	—	-1634	—	—	—	—	—	—	—
	Manifold*	103-	-1522	-2678	—	—	—	—	—	—	-1527

4 Bolt Flange

SHAFT	PORT SIZE	DISPL. cm ³ /r [in ³ /r] / PRODUCT NUMBER										
		59 [3.6]	75 [4.6]	93 [5.7]	120 [7.3]	144 [8.8]	166 [10.1]	187 [11.4]	225 [13.7]	298 [18.2]	372 [22.7]	
1 in. Straight w/Woodruff Key	7/8 -14 O-Ring		103-1625	-1410	-1411	-1626	-2531	-1412	-1413	-1414	-1415	-1416
	1/2 NPTF	103-1644	-1402	-1403	—	—	-1404	-1405	-1406	-1407	-1408	

103-1404

103-1527

*Manifold product numbers shown are for motors with four 5/16 -18 port face mounting threads. Manifold, manifold mounting O-Rings and bolts are NOT included.

For S Series Motors with Low Speed Valving Not Shown in the chart above: Use the model code number system on page B-3-11 to specify the product in detail.



S Series (103-)

Model Code

The following 25-digit coding system has been developed to identify all of the configuration options for the S motor. Use this model code to specify a motor with the desired features. All 25-digits of the code must be present when ordering. You may want to photocopy the matrix below to ensure that each number is entered in the correct box.

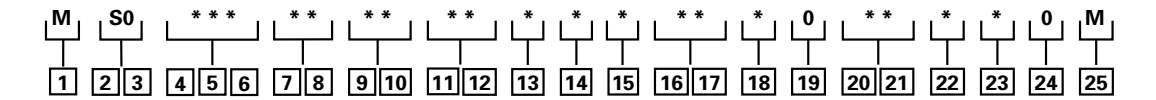

1 Product
M – Motor

2, **3** Series
S0 – S Series Motor

4, **5**, **6** Displacement
cm³/r [in³/r]

036 – 58 [3.6]

046 – 76 [4.6]

057 – 93 [5.7]

073 – 120 [7.3]

088 – 144 [8.8]

101 – 165 [10.1]

114 – 186 [11.4]

137 – 224 [13.7]

182 – 299 [18.2]

227 – 371 [22.7]

7, **8** Mounting Type

AA – 2 Bolt Std: 82.50
[3.248] Dia. x 3.05 [.120]
Pilot, 13.59 [.535] Dia.
Mounting Holes on 106.35
[4.187] Dia. B.C.

BA – 4 Bolt Std: 44.40
[1.748] Dia. x 3.05 [.120]
Pilot, .375-16 UNC-2B
Mounting Holes on 82.55
[3.250] Dia. B.C.

CA – 2 Bolt Std: 82.50
[3.248] Dia. x 6.10 [.240]
Pilot, 10.41 [.410] Dia.
Mounting Holes on 106.35
[4.187] Dia. B.C. (SAE A)

DD – 2 Bolt Std: 101.60
[4.000] Dia. x 6.10 [.240]
Pilot, 14.35 [.565] Dia.
Mounting Holes on 146.05
[5.750] Dia. B.C. (SAE B)
(Ductile)

EA – 4 Bolt Magneto: 82.50
[3.248] Dia. x 3.05 [.120]
Pilot, 13.59 [.535] Dia.
Mounting Holes on 106.35
[4.187] Dia. B.C.

FA – 4 Bolt Std: 44.40
[1.748] Dia. x 3.05 [.120]
Pilot, M10 x 1.5-6h
Mounting Holes on 82.55
[3.250] Dia. B.C.

LA – 2 Bolt Std: 44.45
[1.750] Dia. x 3.05 [.120]
Pilot, 13.59 [.535] Dia.
Mounting Holes on 106.35
[4.187] Dia. B.C.

9, **10** Output Shaft

01 – 25.4 [1.00] Dia.
Straight, Woodruff Key,
.250-20 UNC-2B Hole in
Shaft End

02 – 25.4 [1.00] Dia. SAE
6B Spline, .250-20 UNC-2B
Hole in Shaft End

07 – 25.4 [1.00] Dia.
Straight, 8.03 [.316] Dia.
Crosshole 11.2 [.44] From
End, 5.6 [.22] Extra Length

08 – 25.4 [1.00] Dia.
Straight, 10.31 [.406] Dia.
Crosshole 15.7 [.62] From
End, .250-20 UNC-2B Hole
in Shaft End

16 – 22.22 [.875] Dia. SAE
13 Tooth Spline (SAE B)

17 – 22.22 [.875] Dia.
Straight, 6.4 [.25] x 19.0
[.75] Square Key (SAE B)

18 – 25.4 [1.00] Dia.
Tapered, Woodruff Key and
Nut, 34.92 [1.375] Taper
Length

24 – 25.00 [.984] Dia.
Straight, 8.00 [.315] Key,
M8 x 1.25-6H Hole in
Shaft End

11, **12** Port Type

AA – .875-14 UNF-2B SAE
O-Ring Ports

AB – .500-14 NPTF Dryseal
Pipe Thread Ports

AC – Manifold Ports
(.3125-18 UNC-2B
Mounting Holes)

AD – Manifold Ports (M8 x
1.25-6H Mounting Holes)

AF – G 1/4 BSP Straight
Thread Ports

13 Case Flow Options ††

0 – None Specified

1 – 4375-20 UNF-2B SAE
O-Ring Port (End Cap)

2 – G 1/4 BSP Straight
THD Port (End Cap)

3 – Manifold Case Drain

†† – Internal check valves
are standard features.

14 Geroler Options

0 – None Specified

15 Shaft Options

0 – None Specified

N – Electroless Nickel Plated

16, **17** Seal Options

00 – Standard Seals

02 – Seal Guard

03 – Viton Seals

04 – Viton Shaft Seal

05 – Vented Two-Stage Seal

07 – High Pressure Shaft
Seal

18 Speed Sensor Options

0 – None

A – Speed Sensor Options
12mm Digital Speed Pickup
(15 pulse) without lead wire

B – Magnetic Speed Pickup
(60 Pulse by Quadrature),
No lead wire with M12
connector

(A=Power, B=Common,
C=Signal)

19 Manifold Block
Options

0 – None

* Contact your Eaton sales
representative for available
options.

20, **21** Special Features
(Hardware)

00 – None Specified

AB – Low Speed Valving

SS – Stainless Steel Flange
Bolts

22 Special Assembly
Instructions

0 – None

1 – Reverse Rotation

2 – Flange Rotated 90°

3 – Reverse Rotation, Flange
Rotated 90°

23 Paint/Packaging
Options

0 – No Paint

A – Painted Low Gloss
Black

D – Environmental Coated
Gloss White

F – Environmental Coated
Black

24 Eaton Assigned Code
When Applicable

0 – Assigned Code

25 Eaton Assigned
Design Code

M – Twelve (12)

Feature in **bold** are preferred and
allow for shorter lead time.



Case Pressure and Case Drain — H, S, and T Series

Char-Lynn H Series, S Series and T Series motors are durable and have long life as long as the recommended case pressure is not exceeded. Allowable case pressure is highest at low shaft speeds. Consequently, motor life will be shortened if case pressure exceeds these ratings (acceptability may vary with application). Determine if an external case drain is required

from the case pressure seal limitation chart below — chart based on case pressure and shaft speed. If a case drain line is needed, connect drain line to assure that the motor will always remain full of fluid. A pressure restriction should be added to the case drain line, during which a motor case pressure of 3,5 Bar [50 PSI] is maintained.

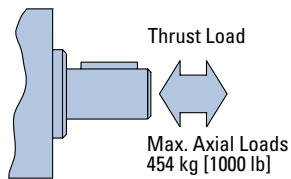

$$P_C \approx 6 \cdot P + P_2$$

P_C = Case Pressure
 P_1 = Inlet Line Pressure
 P_2 = Back Pressure
 $P = P_1 - P_2$

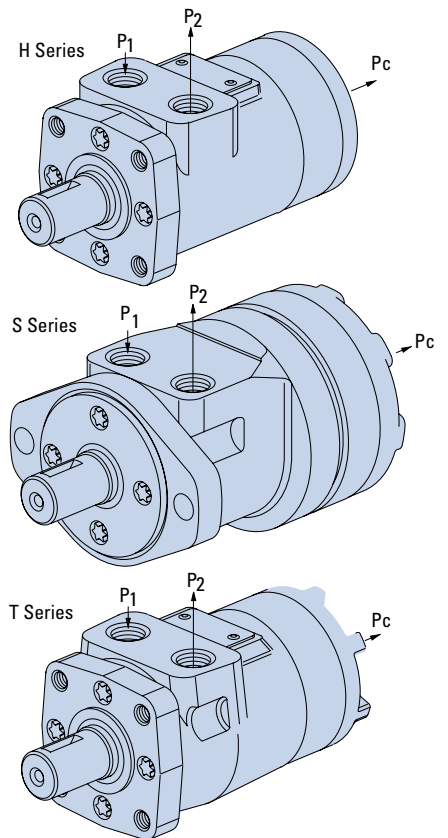
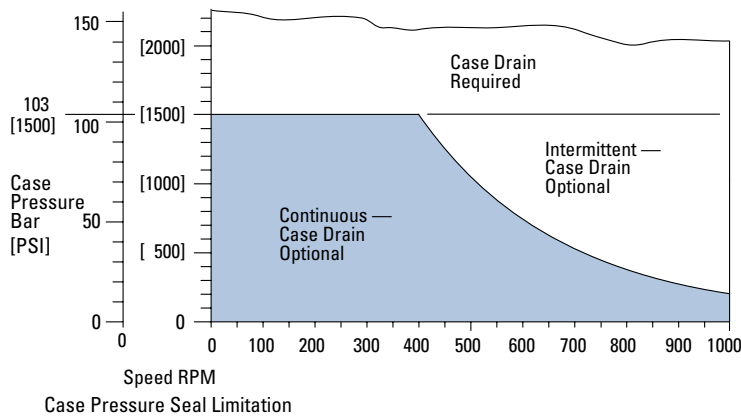



H, S and T Series (101-, 103-, 158-, 185-)

Side Load Capacity

The hydrodynamic bearing has infinite life when shaft load ratings are not exceeded. Hence, the shaft side load capacity is more than adequate to handle most externally applied loads (such as belts, chains, etc.), providing the motor to shaft size is applied within its torque rating.

Allowable side load chart, shaft load location drawing and load curves (below) are based on the side / radial loads being applied to shaft at locations A, B, and C, to

determine the shaft side load capacity at locations other than those shown use the formula (shown below).

For more information about shaft side loads on Char-Lynn motors contact your Eaton representative.

Note:

When the speed sensor option is used, side load ratings are reduced 25%.

RPM	ALLOWABLE SHAFT SIDE LOAD — KG [LB]		
	A	B	C
900	154 [339]	136 [300]	118 [261]
625	205 [452]	181 [400]	158 [348]
500	256 [565]	227 [500]	197 [435]
400	307 [678]	272 [600]	237 [522]
300	410 [904]	363 [800]	316 [696]
200	718 [1582]	635 [1400]	552 [1216]

$$\text{Sideload P kg} = \frac{900}{N} \left(\frac{16800}{L + 96,3} \right) \text{ for 200-900 RPM}$$

$$\text{Sideload P [lb]} = \frac{900}{N} \left(\frac{1460}{L + [3.79]} \right) \text{ for 200-900 RPM}$$

Where N = Shaft Speed (RPM)

L = Distance from Mounting Surface

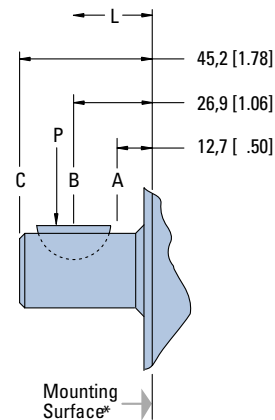
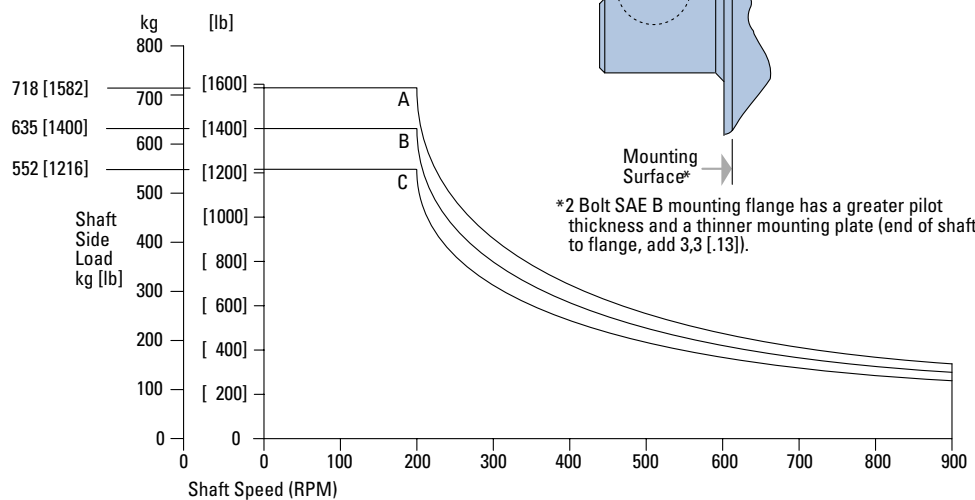



H, S and T Series (101, 103- 158, 185)

Dimensions

Shafts

Shaft Size Motor Torque Combination Limit Guide

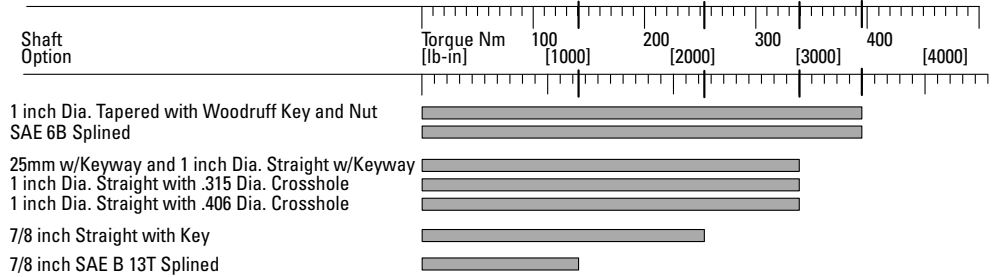

1 in. Dia. Straight with Woodruff Key

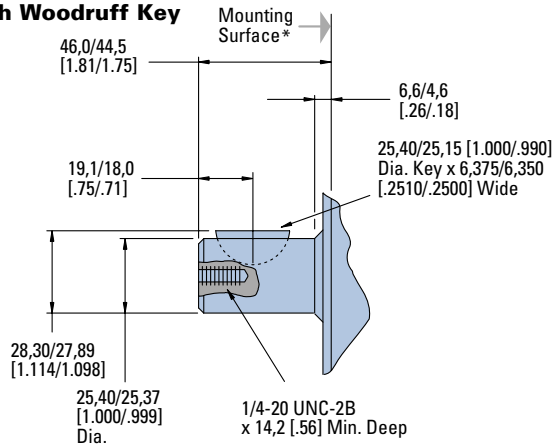

SAE 6B Splined Shaft

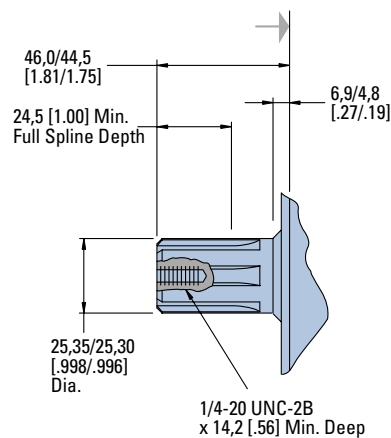

1 in. Dia. Straight Shaft with .315 Dia. Crosshole

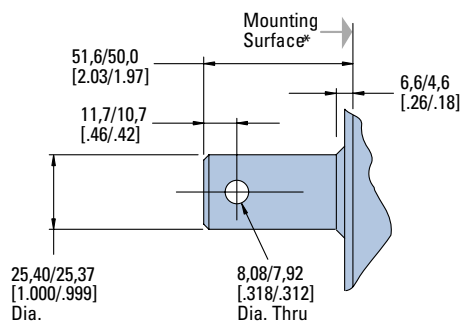

1 in. Dia. Straight Shaft with .406 Dia. Crosshole

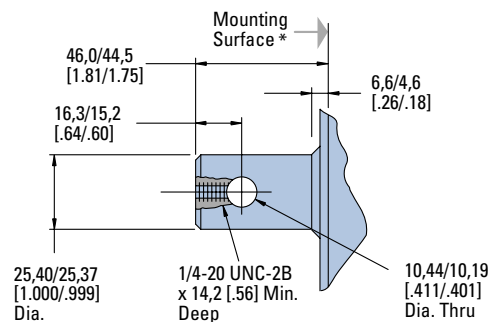

* 2 Bolt SAE B mounting flange has a greater pilot thickness and a thinner mounting plate (end of shaft to flange, add 3,3 [.13]).



H, S and T Series (101-, 103- 158-, 185-)

Dimensions

Shafts

1 in. Dia. Tapered Shaft with Woodruff Key and Nut

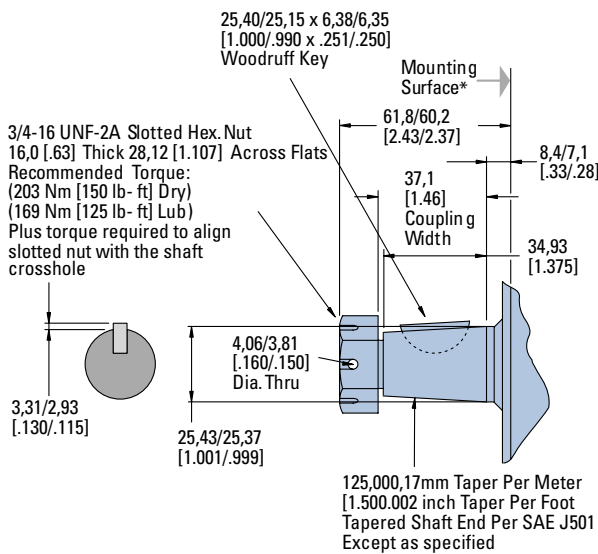

25mm Dia. Straight Shaft with 8mm Keyway

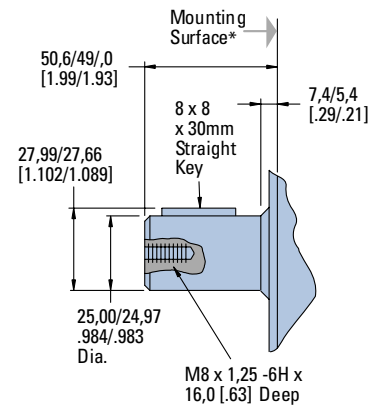

7/8 in. Dia. Straight Shaft with Key

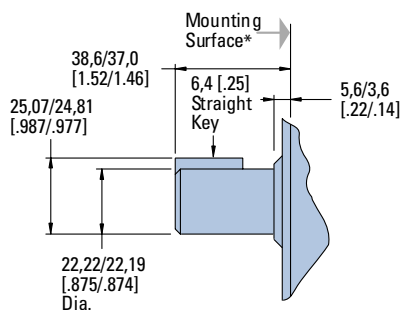

7/8 in. Dia. SAE B Shaft 13 T Spline d

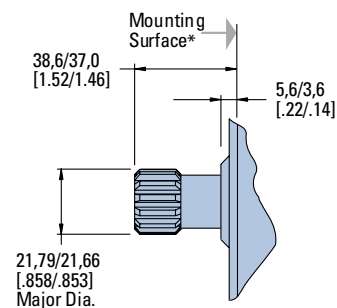

* 2 Bolt SAE B mounting flange has a greater pilot thickness and a thinner mounting plate (end of shaft to flange, add 3,3 [.13]).



H, S and T Series (101-, 103- 158-, 185-)

Mounting Options

Note:

Mounting Surface Flatness Requirement is ∇ ,13mm [.005 inch] Max.

4 Bolt Magneto

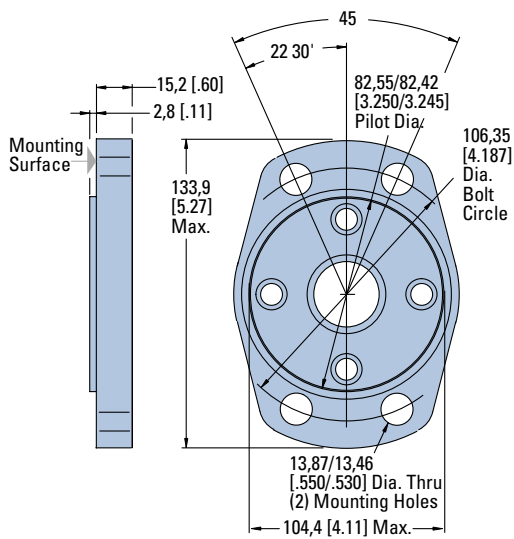

Base Block Mounting Kits

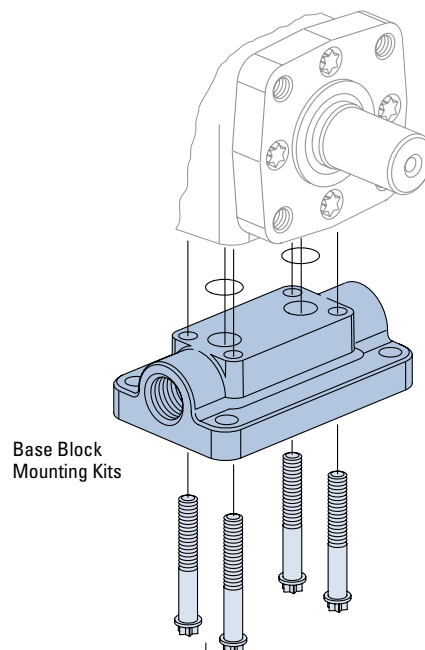

2 Bolt SAE B

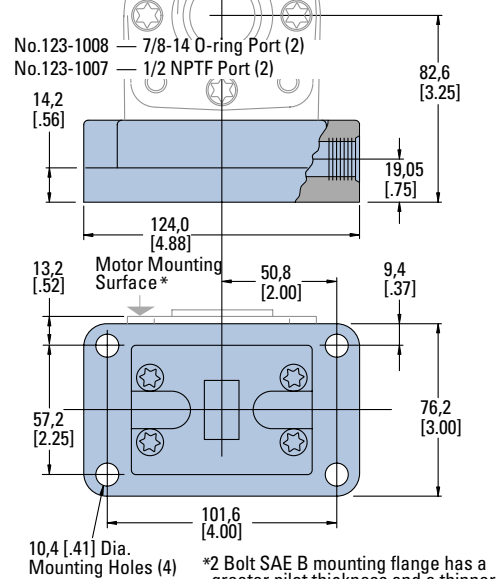
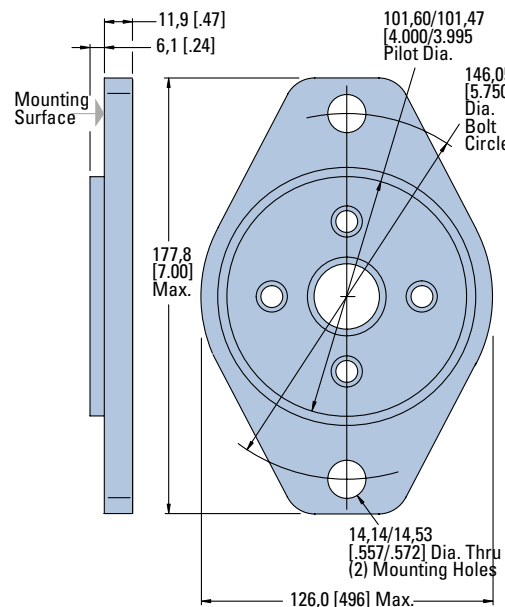



H, S and T Series (101-, 103-, 158-, 185-)

Dimensions

Ports

Ports

End Ports — H Series only
G 1/2 (BSP) (2)
or 3/4-16 O-Ring (2)

Standard Rotation Viewed from Drive End

Port A Pressurized — CW
Port B Pressurized — CCW

Note:

End ported motor pressure is derated. Reference page B-2-2 for ratings.

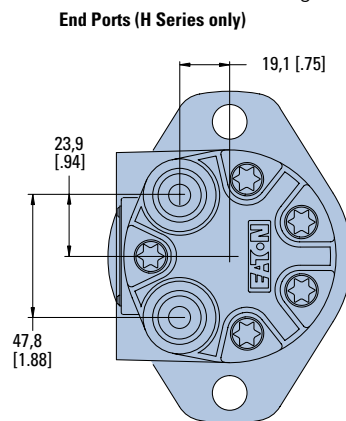
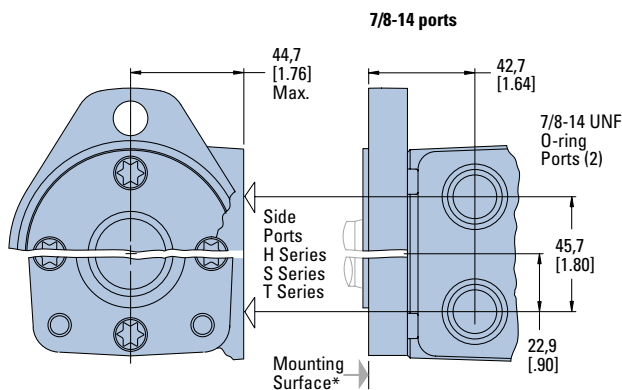

Use of Teflon Tape Sealant/
Lubricant (with 1/2 14 NPTF
Port Connectors only).

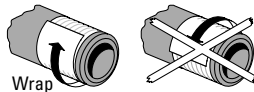

When using fittings with Teflon tape, be careful when taping and tightening. Over tightening or improperly taped fittings can cause damage to housing or leakage.

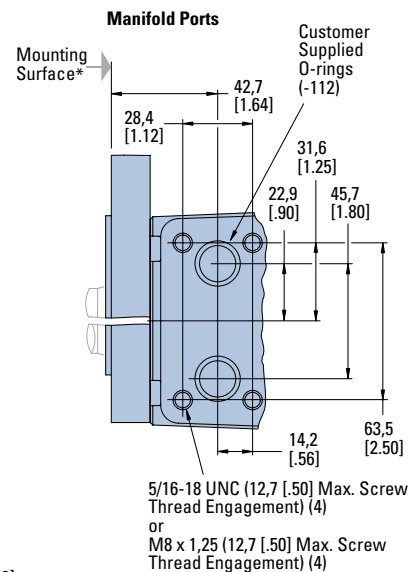
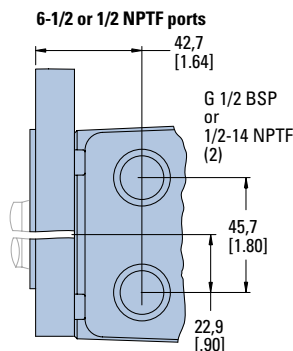

Use the following procedures:

- Wrap approx. 1 1/2 Turns of 13 mm [1/2 in.] wide Teflon Tape around fitting threads — start tape 2 threads up from end of fitting.
- Tighten threads to a Maximum of 34 Nm [25 lb-ft]. — Do Not Tighten Further —
- If fittings leak when tightened to maximum torque, either retape, reseal, or replace fittings.

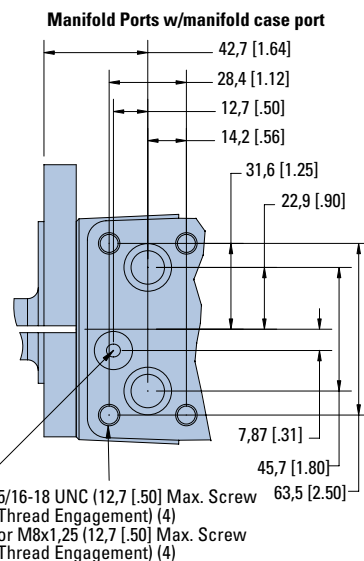

*2 Bolt SAE B mounting flange has a greater pilot thickness and a thinner mounting plate.

Optional Case Drain Port Location (T-Series Only)

5/16-18 UNC (12,7 [0.50] Max. Screw Thread Engagement) (4)
or M8x1,25 (12,7 [0.50] Max. Screw Thread Engagement) (4)

Note:

End ported motor option is derated to 1400 continuous, 1700 psi intermittent.



Order Numbers		
FT Article Number	Eaton Code	Type
1420734	103-1002	CHAR-LYNN MOTOR SERIE S
1248458	103-1003	CHAR-LYNN MOTOR SERIE S
1248459	103-1004	CHAR-LYNN MOTOR SERIE S
1416959	103-1005	CHAR-LYNN MOTOR SERIE S
1248460	103-1008	CHAR-LYNN MOTOR SERIE S
1417088	103-1012	CHAR-LYNN MOTOR SERIE S
1422448	103-1021	CHAR-LYNN MOTOR SERIE S
1424232	103-1026	CHAR-LYNN MOTOR SERIE S
1426081	103-1030	CHAR-LYNN MOTOR SERIE S
1248464	103-1031	CHAR-LYNN MOTOR SERIE S
1248465	103-1032	CHAR-LYNN MOTOR SERIE S
1248466	103-1035	CHAR-LYNN MOTOR SERIE S
1248467	103-1036	CHAR-LYNN MOTOR SERIE S
1416988	103-1037	CHAR-LYNN MOTOR SERIE S
1422393	103-1039	CHAR-LYNN MOTOR SERIE S
1248468	103-1042	CHAR-LYNN MOTOR SERIE S
1333757	103-1043	CHAR-LYNN MOTOR SERIE S
1248469	103-1044	CHAR-LYNN MOTOR SERIE S
1248470	103-1045	CHAR-LYNN MOTOR SERIE S
1418658	103-1046	CHAR-LYNN MOTOR SERIE S
1421872	103-1047	CHAR-LYNN MOTOR SERIE S
1420036	103-1048	CHAR-LYNN MOTOR SERIE S
1418433	103-1408	CHAR-LYNN MOTOR SERIE S
1429277	103-1430	CHAR-LYNN MOTOR SERIE S
1319291	103-1435	CHAR-LYNN MOTOR SERIE S
1432395	103-1436	CHAR-LYNN MOTOR SERIE S
1248475	103-1437	CHAR-LYNN MOTOR SERIE S
1248476	103-1438	CHAR-LYNN MOTOR SERIE S
1248477	103-1439	CHAR-LYNN MOTOR SERIE S
1432108	103-1440	CHAR-LYNN MOTOR SERIE S
1248478	103-1441	CHAR-LYNN MOTOR SERIE S
1330703	103-1444	CHAR-LYNN MOTOR SERIE S
1248479	103-1449	CHAR-LYNN MOTOR SERIE S
1248480	103-1450	CHAR-LYNN MOTOR SERIE S
1248481	103-1451	CHAR-LYNN MOTOR SERIE S
1248482	103-1452	CHAR-LYNN MOTOR SERIE S
1248483	103-1453	CHAR-LYNN MOTOR SERIE S
1248484	103-1454	CHAR-LYNN MOTOR SERIE S
1248485	103-1455	CHAR-LYNN MOTOR SERIE S
1248487	103-1463	CHAR-LYNN MOTOR SERIE S
1248488	103-1464	CHAR-LYNN MOTOR SERIE S-PLUS
1248489	103-1465	CHAR-LYNN MOTOR SERIE S
1248490	103-1466	CHAR-LYNN MOTOR SERIE S-PLUS
1248491	103-1467	CHAR-LYNN MOTOR SERIE S
1248492	103-1468	CHAR-LYNN MOTOR SERIE S
1248493	103-1469	CHAR-LYNN MOTOR SERIE S
1248496	103-1477	CHAR-LYNN MOTOR SERIE S
1248497	103-1478	CHAR-LYNN MOTOR SERIE S
1248498	103-1479	CHAR-LYNN MOTOR SERIE S
1248500	103-1481	CHAR-LYNN MOTOR SERIE S
1433435	103-1482	CHAR-LYNN MOTOR SERIE S
1248502	103-1483	CHAR-LYNN MOTOR SERIE S



Order Numbers		
FT Article Number	Eaton Code	Type
1248503	103-1484	CHAR-LYNN MOTOR SERIE S
1248504	103-1485	CHAR-LYNN MOTOR SERIE S
1248505	103-1486	CHAR-LYNN MOTOR SERIE S
1248506	103-1487	CHAR-LYNN MOTOR SERIE S
1248507	103-1488	CHAR-LYNN MOTOR SERIE S
1248508	103-1489	CHAR-LYNN MOTOR SERIE S
1248509	103-1490	CHAR-LYNN MOTOR SERIE S
1420096	103-1491	CHAR-LYNN MOTOR SERIE S
1248510	103-1493	CHAR-LYNN MOTOR SERIE S
1430903	103-1517	CHAR-LYNN MOTOR SERIE S
1248513	103-1564	CHAR-LYNN MOTOR SERIE S
1340594	103-1565	CHAR-LYNN MOTOR SERIE S
1248514	103-1588	CHAR-LYNN MOTOR SERIE S
1248515	103-1591	CHAR-LYNN MOTOR SERIE S
1248516	103-1592	CHAR-LYNN MOTOR SERIE S
1248517	103-1600	CHAR-LYNN MOTOR SERIE S
1248519	103-1606	CHAR-LYNN MOTOR SERIE S
1248520	103-1607	CHAR-LYNN MOTOR SERIE S
1248522	103-1660	CHAR-LYNN MOTOR SERIE S
1301532	103-1661	CHAR-LYNN MOTOR SERIE S
1248523	103-2004	CHAR-LYNN MOTOR SERIE S
1248524	103-2006	CHAR-LYNN MOTOR SERIE S
1248525	103-2028	CHAR-LYNN MOTOR SERIE S
1248526	103-2030	CHAR-LYNN MOTOR SERIE S
1432497	103-2040	CHAR-LYNN MOTOR SERIE S
1430484	103-2533	CHAR-LYNN MOTOR SERIE S
1248531	103-2724	CHAR-LYNN MOTOR SERIE S
1417283	103-2735	CHAR-LYNN MOTOR SERIE S
1252983	103-2737	CHAR-LYNN MOTOR SERIE S
1314575	103-2801	CHAR-LYNN MOTOR SERIE S
1248534	103-2805	CHAR-LYNN MOTOR SERIE S
1248535	103-2806	CHAR-LYNN MOTOR SERIE S
1248536	103-2807	CHAR-LYNN MOTOR SERIE S
1248537	103-2809	CHAR-LYNN MOTOR SERIE S
1405784	103-3172	CHAR-LYNN MOTOR SERIE S
1405783	103-3173	CHAR-LYNN MOTOR SERIE S